

efficient solutions for heating & cooling





THE COMPANY

Founded in 1970, Frigosystem, the entrepreneurial vision of Sergio Grassi, remains focused on the design, manufacture and sale of industrial chillers. Frigosystem offers an evolved range of products aimed at the most diversified fields of industry: from the numerous activities within plastics to the high tech applications of aeronautics, flexography, converting, packaging and wood applications.

The vocation to innovation, the constant research in technologies and marketing, the application of professional ethics support Frigosystem in its continued growth and in the consolidated cooperation with world renowned OEM's.

Frigosystem, who integrated few years ago a production department dedicated to the temperature control units, is today present in the world with a dense sales and service network.



L'AZIENDA

Frigosystem nasce nel 1970 come missione imprenditoriale di Sergio Grassi. Da sempre focalizzata nella progettazione, costruzione e commercializzazione di refrigeratori industriali, Frigosystem propone la sua evoluta gamma di prodotti a settori diversificati: da quello più vasto dell'industria plastica, a quello altamente tecnico dell'aeronautica, alla flexografica, al converting, al packaging, al legno.

La vocazione all'innovazione, la costante ricerca nelle tecnologie e nei mercati, la valorizzazione dell'etica professionale, hanno sostenuto Frigosystem nella sua crescita e nella consolidata collaborazione con costruttori internazionalmente riconosciuti.

Frigosystem, che ha integrato da qualche anno un reparto produttivo dedicato alla termoregolazione, è presente oggi nel mondo con una fitta rete di vendita e di assistenza tecnica.



DIE FIRMA

Frigosystem wurde 1970 von Sergio Grassi gegründet. Das Hauptgeschäftsfeld ist die Herstellung und der Vertrieb von industriell genutzter Kältetechnik.

Eine gezielte, marktorientierte und kontinuierliche Entwicklung im Bereich der industriell genutzten Prozesskälte stand hier immer im Vordergrund. Prozesskälte sowohl in der Kunststoffverarbeitenden Industrie wie auch in der Drucktechnik, Holzindustrie, Chemie oder im Lebensmittelbereich.

Die ständige, anwendungsorientierte Forschung in Technologien, Seriosität und Zuverlässigkeit haben Frigosystem zu einen anerkannten Lieferanten bei weltweit renommierten Maschinen und Anlagenbauern gemacht.

Seit der Integration der Temperiergerätemarke TCU und COREMA ist Frigosystem auch in dieser Technologie mit einem weltweiten Vertriebs- und Servicenetzwerk präsent.



LA EMPRESA

Frigosystem fue fundada en 1970 como una misión empresarial de Sergio Grassi.

Siempre enfocada en el diseño, construcción y comercialización de Chillers, Frigosystem ofrece una amplia gama de productos para aplicaciones específicas en las diferentes sectores: desde la más grande y creciente industria de los plásticos, a la altamente tecnológica industria de la aviación, así como flexográfica, converting, empaque y maderera.

La vocación por la innovación, la búsqueda constante de nuevas tecnologías que se adaptan a las necesidades del mercado, la alta ética profesional, y el reconocido soporte a los clientes Frigosystem, han sido las razones por las que continua creciendo y consolidando una reputación reconocida por prestigias marcas de OEM's.

Frigosystem, quien integro hace unos años una línea de producción dedicada a la fabricación de Termorreguladores, tiene ahora una fuerte red de ventas y servicio técnico en todo el mundo.



1970

TODAY

GO TRADE



COREMA®
FIRST IN THERMOREGULATION

NATU-RA PORTABLE WATER CHILLERS



SMALL CHILLERS, BIG EFFICIENCY

- Cooling powers from 8 to 60 kW (2 to 17 TON)
- Ecological refrigerant gas R-410A
- Customisable hydronic group: standard version with integrated tank and process pump
- Ambient temperature up to 45°C



KLEINE BAUFORM, GROSSE EFFIZIENZ

- Kühlleistung von 8 zum 60 kW
- Umweltschonendes Kältemittel R-410A
- Kältekomponenten nach Kundenwunsch, Standard Version mit integriertem Tank und Förderpumpe
- Umgebungstemperatur bis zum 45°C



PICCOLI CHILLERS, GRANDI EFFICIENZE

- Potenze di raffreddamento da 8 a 60 kW
- Gas ecologico R-410A
- Gruppo idronico personalizzabile: versione base con vasca e pompa di processo integrate
- Operatività in ambiente fino a 45°C



PEQUEÑOS CHILLERS, GRANDE EFICIENCIA

- Potencia de refrigeración desde 8 hasta 60 kW (8 hasta 17 TON)
- Refrigerante ecológico R-410A
- Grupo hidronico personalizable: version standard con deposito y bomba de proceso integrados
- Operatividad en ambiente hasta 45°C



RACA PLUS ENERGY HIGH EFFICIENCY CHILLERS



- Cooling powers from 40 to 560 kW (11 to 160 TON)
- Ecological refrigerant gas R-410A
- Ambient temperature up to 46°C
- 2 to 4 compressors
- Microchannel condensers



- Potenze di raffreddamento da 40 a 560 kW
- Gas ecologico R-410A
- Operatività in ambiente fino a 46°C
- Unità con 2 o 4 compressori
- Condensatore microcanale



- Kuhlleistung von 40 zum 560 kW
- Umweltschonendes Kältemittel R-410A
- Umgebungstemperatur bis zum 46°C
- 2 oder 4 Kompressoren
- Micro Kanal condensatoren



- Potencia de refrigeración desde 40 hasta 560 kW (11 hasta 160 TON)
- Refrigerante ecológico R-410A
- Operatividad en ambiente hasta 46°C
- 2 o 4 compresores
- Condensador de microcanales



RACA HEAVY DUTY HEAVY DUTY CHILLERS



- Cooling powers from 300 to 2300 kW (85 to 650 TON)
- Ecological refrigerant gas R-134A
- Ambient temperature up to 56°C
- Screw compressors
- Microchannel condensers



- Potenze di raffreddamento da 300 a 2300 kW
- Gas ecologico R-134A
- Operatività in ambiente fino a 56°C
- Compressori a vite
- Condensatore microcanale



- Kuhlleistung von 300 zum 2300 kW
- Umweltschonendes Kältemittel R-134A
- Umgebungstemperatur bis zum 56°C
- Schraubenkompressoren
- Micro Kanal condensatoren



- Potencia de refrigeración desde 300 hasta 2300 kW (85 hasta 650 TON)
- Refrigerante ecológico R-134A
- Operatividad en ambiente hasta 56°C
- Compresores a tornillo
- Condensador de microcanales



REMOTE CONTROLLING
AND MONITORING



ECO
DESIGN
2018 

I-RES MAGNETIC LEVITATION



Top efficient chillers with magnetic levitation compressors

- Cooling powers from 230 to 4700 kW (65 to 1330 TON)
- Ecological refrigerant gas R-134A



Unità ad altissima efficienza con compressori a levitazione magnetica

- Potenze di raffreddamento da 230 a 4700 kW
- Gas ecologico R-134A



Kältemaschinen mit hoher Effizienz und magnetgelagerten Kompressoren

- Kühlleistung von 230 bis 4700 kW
- Umweltschonendes Kältemittel R-134A



Enfriadores de alta eficiencia con compresores de levitación magnética

- Potencia de refrigeración desde 230 hasta 4700 kW (65 hasta 1330 TON)
- Refrigerante ecológico R-134A





E.S.E.E.R.
9,52

H4F HEATING 4 FREE

 Outdoor unit for the simultaneous production of chilled and hot water by means of two independent hydronic circuits

 Gerät zur Aufstellung im Freien für die gleichzeitige Produktion von Kalt und Heißwasser mit zwei unabhängigen Kreisläufen

 Unità da esterno per la produzione simultanea di acqua sia refrigerata che riscaldata tramite due circuiti idronici indipendenti

 Unidad para la producción simultánea de agua refrigerada y caliente gracias a dos circuitos hidráulicos independientes para instalación al exterior



HC-HCA HEATING AND COOLING



- Compact water thermorefrigerator, condensed by water or by air, with multiple thermoregulated zones.
- High accuracy
- Working range temperature from +5°C (41°F) to 90°C (194°F)
- Possibility to work with 2 or more different setting temperatures



- Termorefrigeratore, condensato ad acqua o ad aria, con varie zone termoregolate
- Precisione di controllo della temperatura
- Campo di lavoro da 5 a 90°C
- Possibilità di operare con due o più utenze termoregolate indipendenti



- Kalt-HeiB-Wassertemperiergerate mit wasser- oder luftgekuhlter Kaltmaschine und mehr Temperierzonen
- Hohe Temperaturgenauigkeit
- Temperaturbereich von 5 bis 90°C
- Ermoglicht den Betrieb mit 2 oder mehr Verschiedenen Temperatureinstellungen



- Termochiller compacto, condensado por agua o por aire, con varias zonas de control de temperatura
- Alta precisión
- Amplio rango de temperatura desde +5°C (41°F) hasta 90°C(194°F)
- Posibilidad de ajustar 2 o mas temperaturas diferentes de agua



TRW-TMO WATER AND OIL TEMPERATURE CONTROL UNITS

WATER AND OIL TEMPERATURE CONTROL UNITS

- Wide range
- Heating power from 3 to 300 kW
- Operating temperature range from 30°C to 350°C (86° F to 662° F)
- Modbus, Profibus, RS485 communication facility
- Reduced maintenance

TERMOREGOLATORI AD ACQUA E A OLIO

- Ampia gamma
- Potenze da 3 a 300 kW
- Campi di lavoro da 30 a 350°C
- Possibilità di comunicazione Modbus,
- Profibus, RS485
- Minima manutenzione

WASSER UND THERMALTEMPERIERGERAT

- GroBe Einsatzbereiche
- Heizleistung von 3 KW bis 300 KW
- Betriebstemperaturen von 30° C bis 350° C
- RS485 Modbus, Profibus/net oder Analog-Interface
- Wartungsfreundlicher Aufbau

TERMORREGULADORES AGUA Y ACEITE

- Amplia gama
- Potencia de calefacci6n desde 3 KW hasta 300 KW
- Rango de temperaturas desde 30° C hasta 350° C (86° F hasta 662° F)
- Comunicaci6n Modbus, Profibus y RS485
- Minimo mantenimiento



PUMPING SYSTEMS



PUMPING SYSTEMS

Designed to provide the highest efficiency on refrigeration and thermoregulation fluid circulation.

Centrifugal pumps and configurations with standby, parallel or variable speed pumps

Modular and robust structure in AISI409

Totally insulated water reservoir

Thermal insulation on all hydraulic connections and collectors

Electrical board for pumps and temperature control



PUMPSTATIONEN

Gebaut um die höchste Wirkung in Kühlung und Temperierung des Umlaufmediums zu gewährleisten.

Zentrifugalpumpen mit Einstellungen für Standby Modus, Parallelschaltung und variable Geschwindigkeiten.

Modulare und sehr robuste Stahlrahmen AISI 409

Vollisolierter Wassertank

Schutzisolation an allen hydraulischen Verbindungen und Wannen

Schaltschrank für Pumpe und Temperaturregelung



GRUPPI DI POMPAGGIO

Massima efficienza nella circolazione del fluido negli impianti di refrigerazione o di termoregolazione.

Pompe centrifughe, in stand-by, in parallelo o a portata variabile con inverter

Basamento in acciaio inossidabile AISI409 modulare e di elevata robustezza

Serbatoio di accumulo in acciaio totalmente coibentato

Coibentazione termica di tutti i collegamenti idraulici e collettori

Quadro elettrico per la gestione ed il controllo delle pompe e delle temperature



SISTEMAS DE BOMBEO

Diseñados para garantizar la máxima eficiencia de la circulación del fluido en plantas de refrigeración y termorregulación.

Bombas centrífugas y configuraciones con bombas en stand-by, en paralelo o con caudal variable e inverter

Estructura modular y robusta en acero inoxidable AISI409

Tanque de agua totalmente aislado

Aislamiento térmico en todas las conexiones y los colectores hidráulicos

Cuadro eléctrico para el control de las bombas y de temperaturas



KITE-KITE DEX-KBFC COOLING TECHNOLOGIES FOR BLOWN FILM



- Wide range of cooling solutions for blown film extruders, including IBC/OBC air cooling, water thermoregulation for extruders, winders, motors, haul-off and electrical cabinets conditioners.
- Easy regulated air flows with high temperature accuracy
- Energy saving
- Droplet separator



- Ampia gamma di soluzioni per estrusori film in bolla, sia per il raffreddamento dell'aria anello e IBC, sia per la termoregolazione dell'acqua alle utenze (estrusori, avvolgitori, motori, traini) e per il condizionamento degli armadi elettrici
- Portate d'aria altamente regolabili ed altissima precisione di temperatura
- Risparmio energetico
- Separatore di goccia



- Umfangreiche Lösungen für die Kühlung und Temperierung von Blasfolienanlagen, inklusive IBC/OBC Kühlung, Wassertemperaturregelung für Extruder, Wickler, Motoren, Abzugswalzen und Klimageräte für Schaltschränke.
- Bedienerfreundliche Steuerung der Kühlluft mit hoher Genauigkeit.
- Energiesparend
- Kondensatabscheider



- Amplia gama de soluciones para extrusoras de película soplada, tanto para el enfriamiento del aire del anillo y del IBC, como para la termorregulación del agua para los usuarios (extrusoras, bobinadoras, motores, tiros) y para el acondicionamiento de los armarios eléctricos
- Flujos de aire altamente ajustables y precisión de temperatura muy alta
- Ahorro de energía
- Separador de gotas



FROM **35% TO 90%**

ENERGY SAVING WITH
- ECO-FRIENDLY REFRIGERANT GAS R410A
- FREE-COOLING OPTION



REMOTE CONTROLLING
AND MONITORING



ACE ADIABATIC COOLING ENERGY

- Lower environmental impact, with regard to energy consumption and noise level
- Lower water consumption by up to 95% when compared to a traditional cooling tower
- Lower costs for chemical treatments
- Lower cost for maintenance
- Maximum efficiency due to special due to Frigosystem patented design

- Die Umweltbelastung wird verringert durch niedrigen Energieverbrauch und geringere Geräuschemissionen
- Im Vergleich zum Verrieselungskühlturm bis zu 95% Wasserersparnis
- Geringere Chemiekosten bei der Wasseraufbereitung
- Geringere Wartungskosten
- Die von Frigosystem patentierte Konstruktion erlaubt maximale Effizienz

- Basso impatto ambientale legato ai consumi energetici e di rumorosità
- Ridotto consumo di acqua fino al 95% rispetto ad una torre evaporativa
- Bassi costi correlati al trattamento chimico dell'acqua
- Bassi costi di manutenzione
- Massimo rendimento con abbattitore brevettato Frigosystem

- Bajo impacto ambiental, debido al bajo consumo energético y bajo nivel de ruido
- Hasta 95 % menos consumo de agua comparado con una torre de enfriamiento
- Menores costos relacionados con el tratamiento químico del agua
- Bajo costo de mantenimiento
- Máximo rendimiento gracias a la sección adiabática patentada de Frigosystem

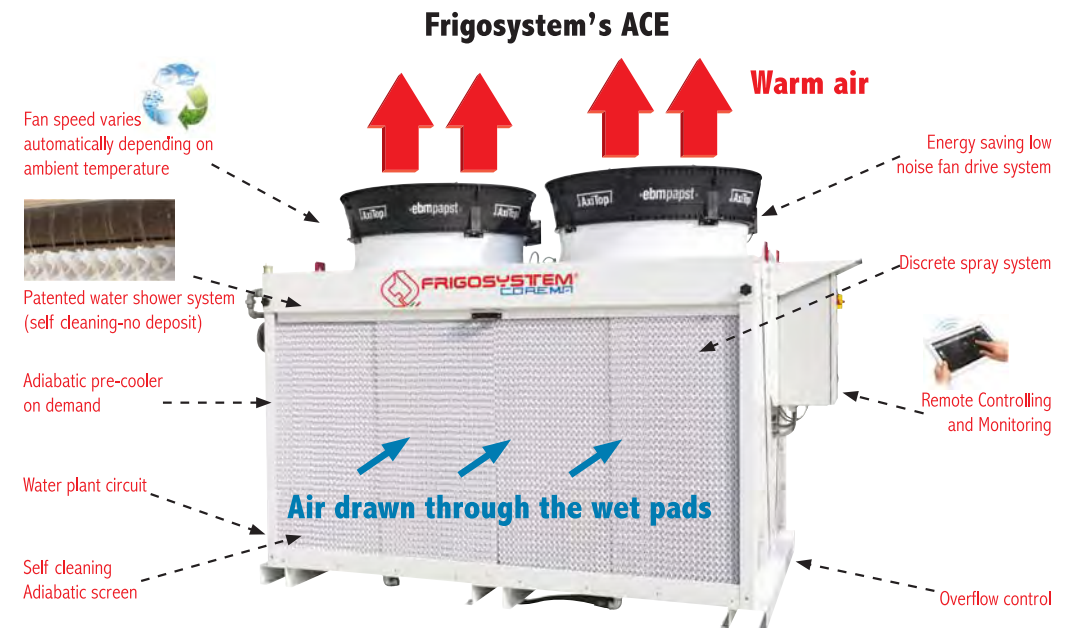
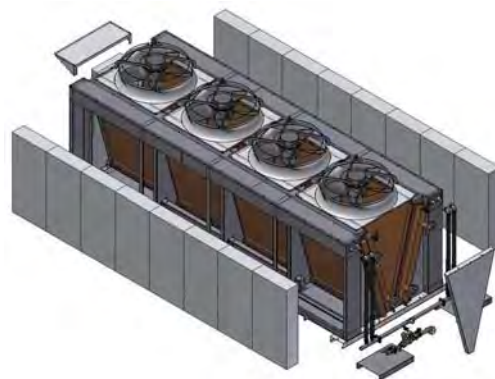



Units with ATEX conformity for applications in explosive atmosphere (Atmospheres Explosibles)
EXPLOSION PROOF _ Zone 2 3G IIB T3

Conditioners

- Shelter pressurization and conditioning
- Ambient temperature control in air cooling and dehumidification

Temperature controllers

- Pressurized water electrical heating
- Indirect cooling

Chillers

- Water and/or air cooled
- Suitable for high ambient temperature



Geräte mit ATEX Zulassung zur Anwendungen in Explosionsgefährdeten Bereichen
EXPLOSIONSSCHUTZ _ Zone 2 3G IIB T3

Klimaanlagen

- Überdruckerzeugung und Klimatisierung in Containern
- Raumklimatisierung und Entfeuchtung

Temperiergeräte

- Druckwassergeräte mit elektrischer Heizung
- Indirekt gekühlte Temperiergeräte

Kältemaschinen

- Wasser und Luftgekühlt
- Maschinen für hohe Umgebungstemperaturen



Units with ATEX conformity for applications in explosive atmosphere (Atmospheres Explosibles)
EXPLOSION PROOF _ Zone 2 3G IIB T3

Conditioners

- Shelter pressurization and conditioning
- Ambient temperature control in air cooling and dehumidification

Temperature controllers

- Pressurized water electrical heating
- Indirect cooling

Chillers

- Water and/or air cooled
- Suitable for high ambient temperature



Unità a norme ATEX per applicazioni in atmosfera esplosiva (Atmospheres Explosibles)
ANTIDIFLAGRANTE _ Zone 2 3G IIB T3

Climatizzatori

- Pressurizzazione e condizionamento per shelter
- Controllo temperatura ambiente in raffreddamento e deumidificazione dell'aria

Termoregolatori

- Riscaldamento elettrico acqua pressurizzata
- Raffreddamento indiretto

Refrigeratori

- Condensazione ad aria o ad acqua
- Adatti ad operare ad alte temperature ambiente



CLEAN ROOMS

 Customized solutions for manufacturing and logistic environments in controlled atmosphere. Particularly appropriate for the production of food, medical and cosmetics packaging.

 Kundenspezifische Lösungen für Produktions- und Lagerstandorte mit Schutzatmosphäre. Besonders geeignet für die Produktion von Lebensmittel- Pharma- und Kosmetikverpackungen.

 Soluzioni personalizzate per la gestione, in atmosfera controllata, di ambienti produttivi e logistici. Particolarmente indicate nella produzione di packaging alimentare, medicale e cosmetico.

 Soluciones personalizadas para la gestión, en atmósfera controlada, de entornos de producción y logística. Muy apropiadas para la producción de envases de alimentos, médicos y cosméticos.

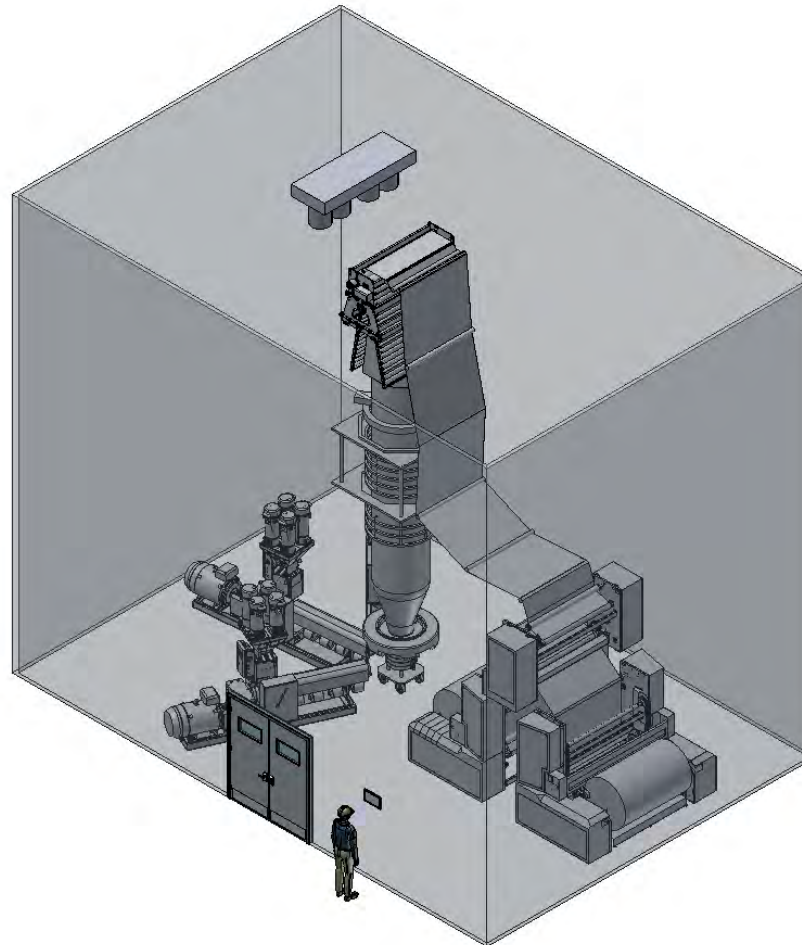

GLOBAL PRESENCE

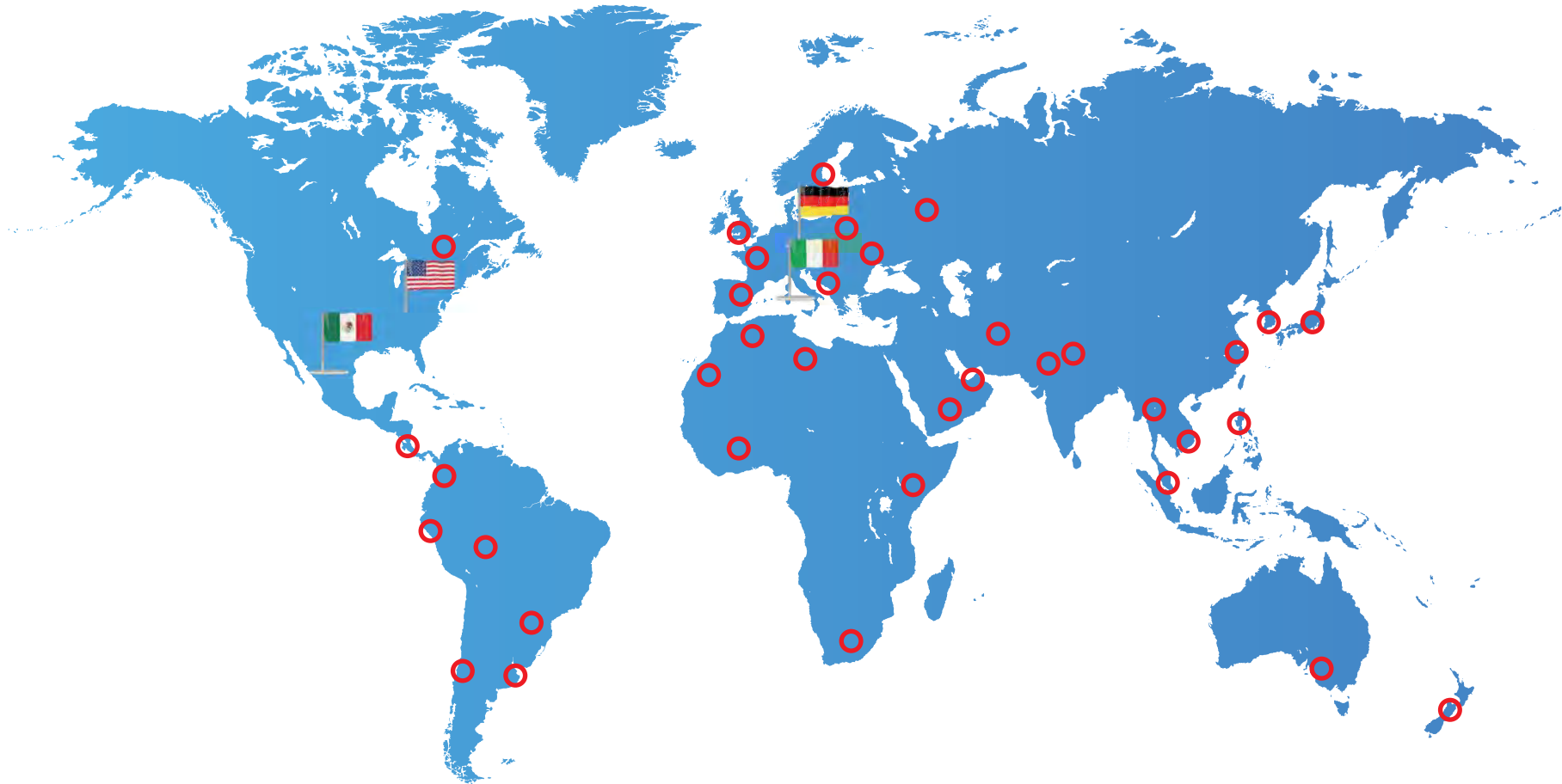

FRIGOSYSTEM S.R.L. (HEADQUARTER)
VIA J.F. KENNEDY 240
21042 CARONNO PERTUSELLA (VA)
ITALY
+39 02 9658610



GO TRADE MX S. DE R.L. DE C.V.
AVENIDA DE LAS FUENTES NO.70,COL.
PARQUE INDUSTRIAL FINSA
C.P.76246 EL MARQUES - QUERETARO
MEXICO
+52 4422215867



GO TRADE NORTH AMERICA INC.
940 SCIENCE BLVD SUITE C
GAHANNA OH 43230-6664
COLUMBUS, U.S.A.
+1 614 601 8037



GO TRADE GERMANY GMBH
FRIEDRIKE-FLIEDNER-WEG 12,
40489 DÜSSELDORF
GERMANY
+49 1515 3333 498



FRIGOSYSTEM S.r.l.
Via J.F. Kennedy 240
21042 Caronno Pertusella (VA) - ITALY
Tel. +39 02 9658610 - Fax +39 02 9650723
info@frigosystem.it - www.frigosystem.it